

Operating Instructions

Wired Remote Control Unit CA-RC3000EU

Find the model number and serial number on either the back or bottom of the unit. Please record them in the space below and retain this booklet as a permanent record of your purchase to aid in identification in case of theft.

MODEL NUMBER CA-RC3000EU
SERIAL NUMBER _____
DATE PURCHASED _____
FROM _____

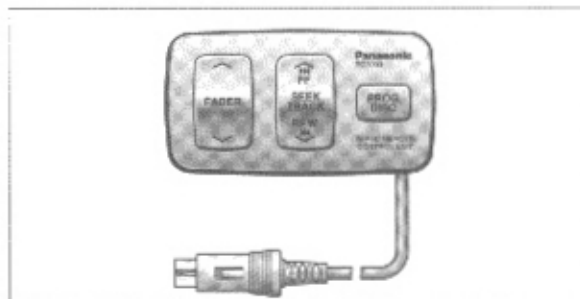

Panasonic®

Please read these instructions completely before operating this unit.

Main Features

- This is wired remote control unit for mainly using with Panasonic Cassette/CD Receiver (CQ-3650EU/CQ-3700EU) by connecting it for your listening enjoyment.
- If you install this controller in the sleeper room in your truck, this setting is the good for your rest by lying on with listening to music.

Names of Operation Buttons

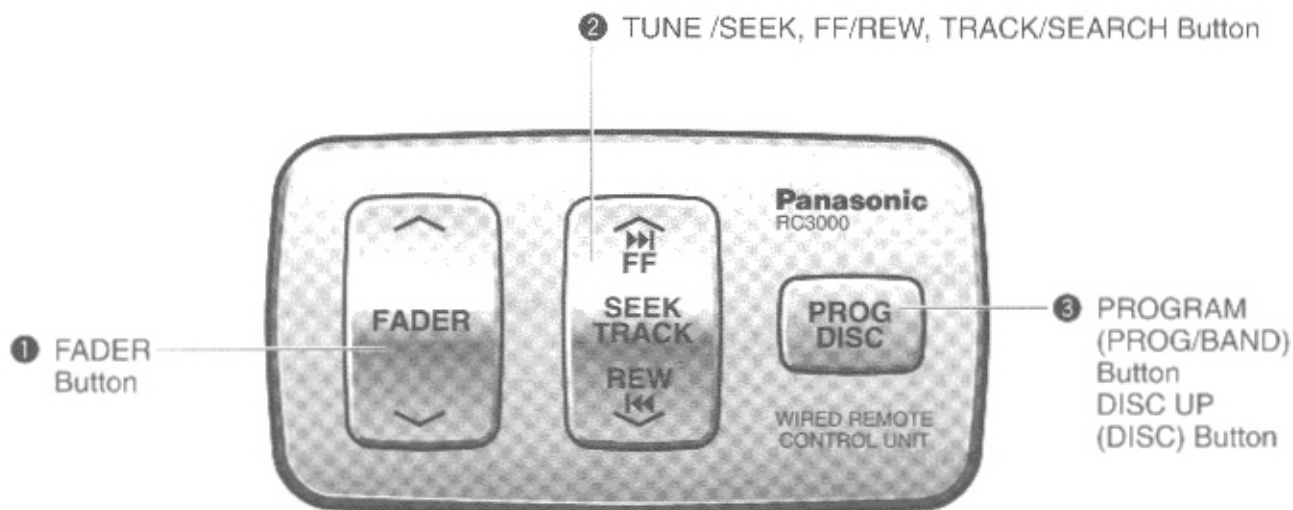

Cassette Tape Player (Only for CQ-3650EU)

Rewind and Fast Forward

②   (Rewind/Fast Forward Button)

- Press “◀◀” or “▶▶” to rewind or fast forward the tape.

③ PROG (Stop/Play Button)

- Press PROG to stop rewind or fast forward.
- The tape will resume playing from that position.



Changing Side

③ PROG (Program Change Button)

Press PROG to switch to the program on the other side of tape.

Compact Disc Player (Only for CQ-3700EU)

Selecting a Track

②   (Track / Search Button)

- Press “▶▶” once to go to the next track.
- Press “◀◀” once to play from the beginning of the currently played track.
- Press repeatedly to skip the desired number of tracks.
- Press and hold “▶▶” or “◀◀” for more than half second to activate fast forward or reverse through a track.

Specifications

Dimensions (WxHxD)	: 9 5/16" x 2 9/32" x 1 9/32" (110 x 58 x 14.8 mm)
Weight	: 1 lbs. 5 oz (600 g)
Current Consumption	: 30mA
Illumination	: LED (Light-Emitting Diode)
(Connectable Unit)	: (CQ-3650/3700EU)

**Panasonic Consumer Electronics
Company, Division of Matsushita
Electric Corporation of America**
One Panasonic Way, Secaucus,
New Jersey 07094

Operating Procedures

General

Fader Volume

① **∇ FADER ^**

(Fader Volume Control Button)

Press “^” or “∇” to shift the sound volume to the front or rear speakers.

CAUTION:

When changing sound volume level for the rear side speakers by using FADER button of the wired remote control unit (CA-RC3000EU), it may occur that a sudden change in volume from the front side speakers. So, pay attention when you adjust the volume.

Radio

Selecting a Band

③ **PROGRAM (PROG/BAND Button)**

Press PROG (BAND) to select the bands in the following order.

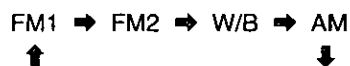

Manual Tuning

② **∇ TUNE ^ (Tuning Button)**

Press “∇” or “^” to move to a lower or higher frequency.

Seek Tuning

② **∇ SEEK ^ (Tuning Button)**





Press and hold “∇” or “^” for more than a half second, then release. The radio automatically stops on the next station.

CD Changer Control (Only for CQ-3650EU)

(In connection with the CD Changer)

Selecting a Track

② **TRACK  TRACK  (Track / Search Button)**

- Press “” once to go to the next track.
- Press “” once to play from the beginning of the currently played track.
- Press repeatedly to skip the desired number of tracks.
- Press and hold “” or “” for more than half second to activate fast forward or reverse through a track.

Selecting a DISC

③ **DISC UP (DISC Button)**





- Press DISC to sequentially advance to the next DISC.
- Press repeatedly to skip the desired number of discs.

Installation Guid

1. Installation of the Control Unit

Install this Control Unit in the sleeper room of your truck.

2. Installation Hardware

NO.	Item	Diagram	Q'ty.	NO.	Item	Diagram	Q'ty.
1	Bolt (5mmø x 25)		2	4	Extension Cord (4 m)		1
2	Hex. Nut (5mmø)		2	5	Washer (5 mmø)		2
3	Extension Cord (3m)		1				

■ Installation Procedures

- ① Fit up the bolts to the two buried nuts (placed A and B) in the back side of the unit by using a screwdriver.
- ② Make two holes on the installation panel in the sleeper room to put into the bolts.
- ③ Make a hole on the installation panel in the sleeper room to put through cord.
- ④ Mount the unit on the bord in the sleeper room by fixing the two place with the Hex. nuts.

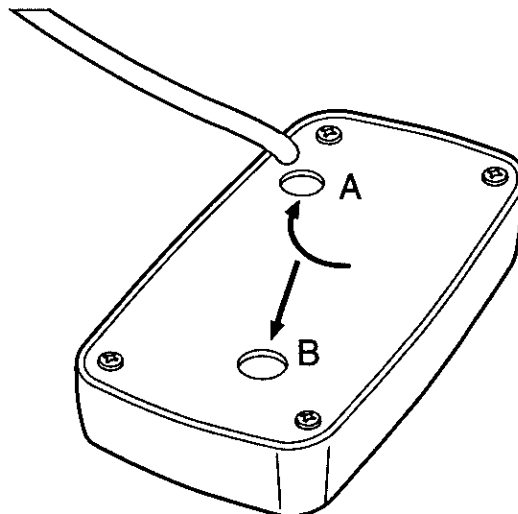

<Back side of the unit>

Electrical Connection

CQ-3650/3700EU System Up

For connection to CQ-3650EU or CQ-3700EU, refer to operating instructions of the those.

Caution:

- To prevent damage to the unit, be sure to follow the connection diagram above.
- Be sure to connect the ground lead (black) of the Cassette or CD Receiver to the vehicle chassis first before connecting the other leads to the specified wires of the vehicle.
- Be sure to insulate any exposed wires from a possible short-circuit from the vehicle chassis. Bundle all cables and Keep cable terminals free from touching any metal parts.

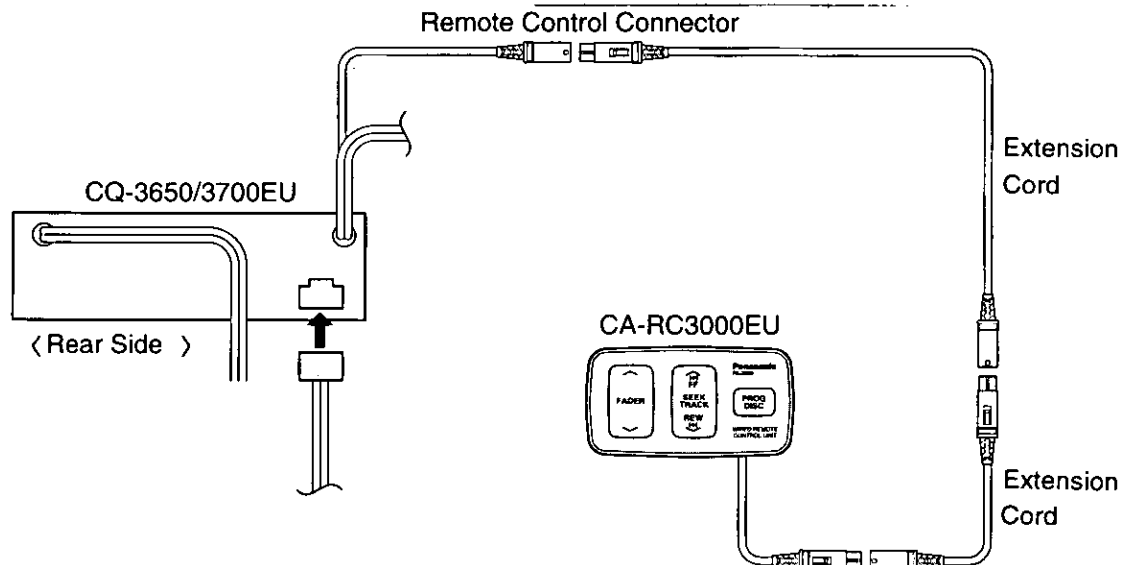

Example for Installation position

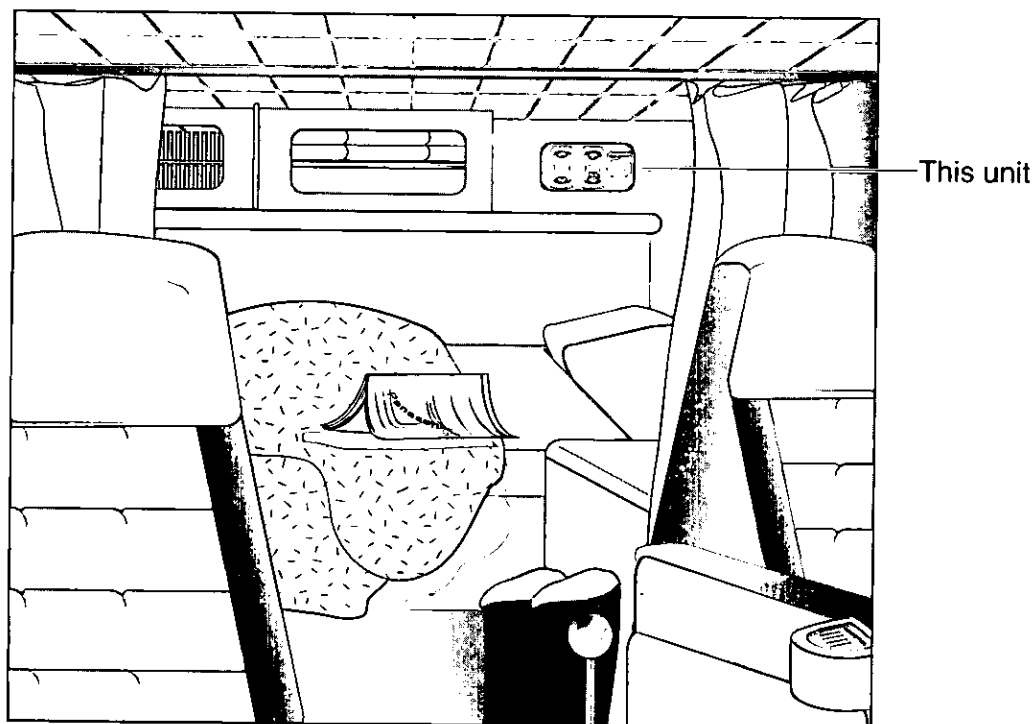

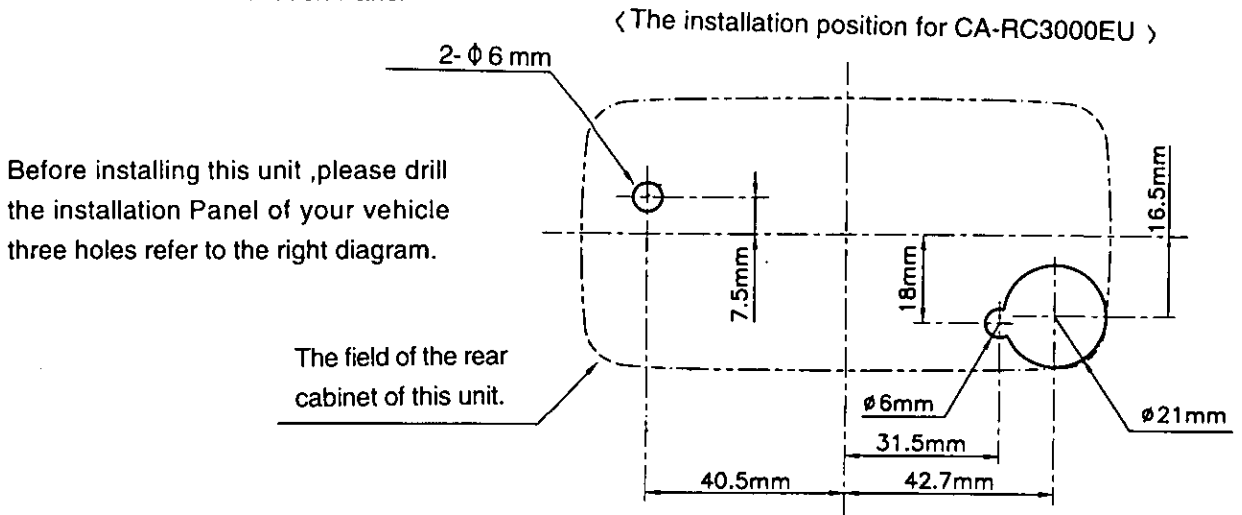
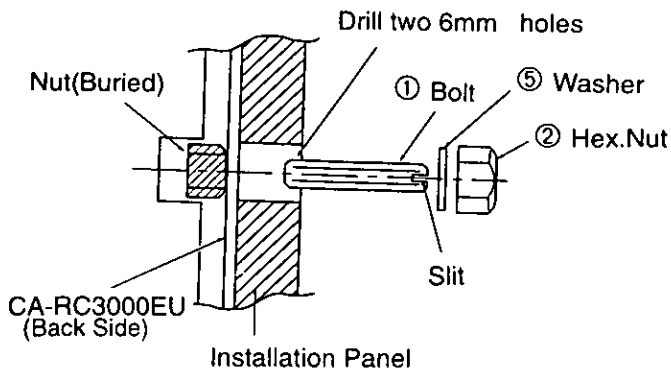

Troubleshooting

Maintenance

Your product is designed and manufactured to ensure a minimum of maintenance. Use a soft cloth for routine exterior cleaning. Never use benzine, thinner, or other solvent.

Product Servicing

If you don't solve the problem, we recommend that you take it to your nearest authorized PASC Servicenter. The unit should be serviced only by a qualified technician.



WARNING

This installation information is designed for experienced installers and is not intended for non-technical individuals. It does not contain warnings or cautions of potential dangers in attempting to install this product.

Any attempt to install this product in a motor vehicle by anyone other than qualified installer could cause damage to the electrical system and could result in serious personal injury or death.